

Electro-Voice®
a gulton company

Model RE15 Variable-D® Dynamic Super-Cardioid Microphone

SPECIFICATIONS

Element:

Dynamic

Frequency Response:

80–15,000 Hz

Polar Pattern:

Super-cardioid

Impedance:

Lo-Z (150 ohms nominal)

Output Level:

–56 dB

(0 dB = 1 mW/10 dynes/cm²)

EIA Sensitivity:

–150 dB

Diaphragm:

Electro-Voice Acoustalloy®

Case Material:

Steel

Dimensions:

167 mm (6.57") long,

35 mm (1.38") diameter,

19 mm (.75") shank diameter

Finish:

Fawn beige micomatte

Net Weight:

170 g (6 oz), not including cable

Cable:

4.6 m (15'), 2-conductor shielded, broadcast-type cable, rubber-jacketed with Switchcraft A3F connector

Accessories Furnished:

Model 310A stand adapter

Protective vinyl carrying pouch

Optional Accessories:

Model 307 suspension mount

Model 312A stand adapter

Model 313A shock mount

Model 314 windscreen

Model 340 & 342 stud adapters

Model 400 or 422 desk stand

DESCRIPTION AND APPLICATIONS

The Electro-Voice Model RE15 is a Variable-D® dynamic cardioid microphone created specially for the most exacting professional applications. Utilizing the major technological breakthrough of Variable-D design (a means for deriving directionality), the RE15 features a degree of directional control so effective that frequency response is virtually independent of angular location of sound source. The result is a microphone that generates little or no off-axis coloration, yet provides greatest possible rejection of unwanted sounds. A super-cardioid, the RE15 provides its greatest rejection at 150° off axis. (Typical cardioids provide greatest rejection at 180°). This assures greatest rejection in the horizontal plane when the microphone is tilted in its most natural position—30° from horizontal (as on a boom or floor stand). An easily operated "bass-tilt" switch corrects spectrum balance for boom use and other longer reach situations.

An additional advantage of the unique Variable-D design is the near elimination of proximity effect. All Single-D microphones exhibit a proximity effect (bass boost) when the microphone is closer than 12 inches to the sound source. The RE15 Variable-D reduces proximity effect from the Single-D microphone's typical 15 dB at 100 Hz to less than 5 dB at 100 Hz.

A "hum-buck" coil has been added to the RE15 (See Fig. 4), in addition to its screw-machined steel outer casing, to

ensure rejection of hum under all conditions. When a dynamic microphone is subjected to extremely heavy magnetic fields such as those caused by AC currents due to heavy stage lighting, proximity to power transformers, or many other conditions which occur under remote operation, it has a tendency to pick up hum. The hum-buck coil in the RE15 gives an additional 25 dB of hum rejection. Hum pickup level is –125 dB (re: .001 gauss field).

Using the mechanical nesting concept of design—by means of which the internal transducer parts are nested one within another—the RE15 transducer is a nearly solid mechanical structure that is highly resistant to damage from mechanical shock. The exclusive non-metallic Electro-Voice Acoustalloy® diaphragm is virtually unaffected by extremes of atmospheric conditions. A carefully designed steel outer case provides excellent magnetic shielding and additional mechanical protection. Finish is fawn beige micomatte.

ARCHITECTS' AND ENGINEERS' SPECIFICATIONS

The microphone shall be a Variable-D® super-cardioid dynamic type with wide range response uniform from 80-15,000 Hz. Proximity effect shall be 10 dB less at 100 Hz than with comparable Single-D designs. Response at any angular position away from the major axis shall be essentially similar to the response on the major axis, attenuated uniformly at all frequencies by an

amount appropriate to that angular position. Attenuation at frequencies from 100 to 4,000 Hz (referred to major axis signal value) shall exceed 25 dB at 150° from major axis in any plane. Attenuation above 4,000 Hz shall exceed 20 dB. Attenuation at 180° from major axis in any plane at frequencies from 100 to 4,000 Hz shall exceed 15 dB. Above 4,000 Hz, attenuation shall exceed 12 dB. Polar characteristic shall be sufficiently uniform in all planes so that it is, effectively, a super-cardioid of revolution.

An integral passive filter network shall be provided such that when filter switch is in "on" position, low-frequency response shall be so deviated from "flat" response that a fall of 6 dB from 1000 to 100 Hz shall be effected. With switch in "off" position, microphone shall be essentially "flat" from 100 to 15,000 Hz, with a 6 dB rise in response from 50 to 100 Hz. Output level shall be -56 dB (0 dB = 1 mW/10 dynes/cm²), and EIA sensitivity rating shall be -150 dB. The diaphragm shall be non-metallic Acoustalloy® and shall have a magnetic shield to prevent dust

and iron particles from reaching the diaphragm.

The case shall be made of steel. The microphone shall have a maximum diameter of 35 mm (1.38"), with 19 mm (.75") diameter shank, and a maximum length of 167 mm (6.57"), not including cable connector. Finish shall be fawn beige micomatte. A 4.6 m (15'), 2-conductor shielded, broadcast-type, rubber-jacketed cable with Switchcraft A3F connector installed shall be provided. The microphone shall have a built-in connector similar or equivalent to the Switchcraft A3M. A Model 310A stand adapter and metal carrying case shall be supplied. The Electro-Voice Model RE15 is specified.

WARRANTY (Limited) — Electro-Voice Professional Broadcast, Recording, and Sound Reinforcement Microphones are guaranteed unconditionally against malfunction from any cause for a period of two years from date of original purchase. Also, these microphones are guaranteed without time limit against malfunction in the acoustic system due to defects in workmanship and materials. (Any active

electronics incorporated in a microphone are guaranteed for three years from date of original purchase against such malfunction.) If such malfunction occurs, microphone will be repaired or replaced (at our option) without charge for materials or labor if delivered prepaid to the proper Electro-Voice service facility. Unit will be returned prepaid. Warranty does not cover finish, appearance items, cables, cable connectors, or switches. Defect guarantee does not cover malfunction due to abuse or operation at other than specified conditions. Repair by other than Electro-Voice or its authorized service agencies will void this guarantee.

For repair information and service locations, please write: Service Department, Electro-Voice, Inc., 600 Cecil Street, Buchanan, Michigan 49107 (Phone 616/695-6831) or 7473 Avenue 304, Visalia, CA 93277 (209/625-1330,-1).

Electro-Voice also maintains complete facilities for non-warranty service of E-V products.

Specifications subject to change without notice.

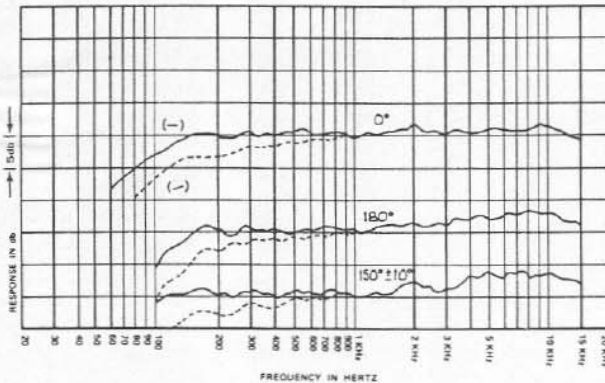

FIGURE 1 - Frequency Response

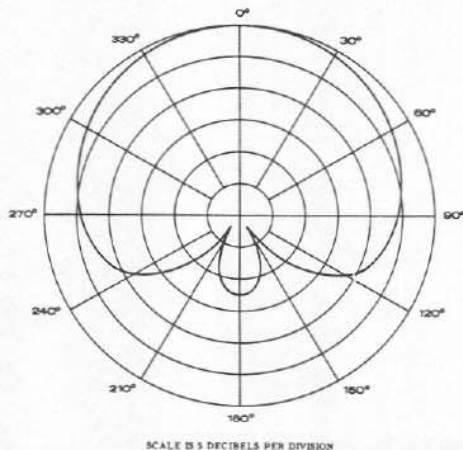

FIGURE 3 - Polar Response

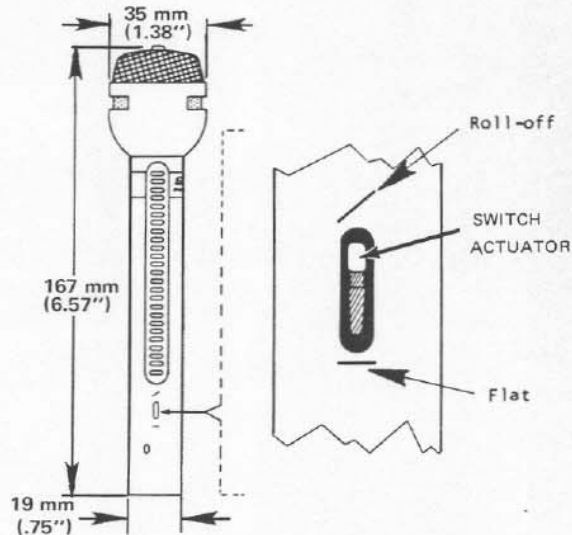

FIGURE 2 - Dimensions

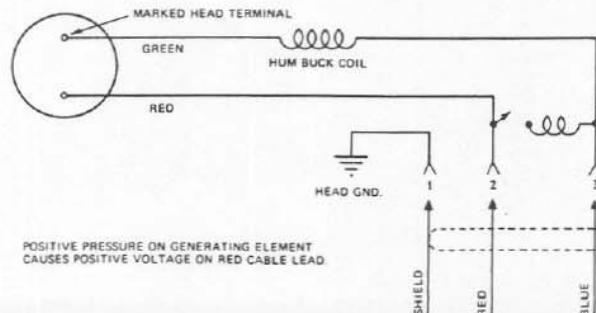

FIGURE 4 - Wiring Diagram